

Description

The MPC-155E series combine an AlGaAs infrared emitting diode as the emitter which is optically coupled to an integrated circuit with a power output stage in a plastic SOP5 package with different lead forming options.

Features

- High isolation 3750 VRMS
- DC input with a high speed driver
- Operating temperature range - 40 °C to 100 °C

Applications

- Isolated IGBT/Power MOSFET gate drive
- Industrial Inverter
- AC brushless and DC motor drives
- Induction Heating

SCHEMATIC

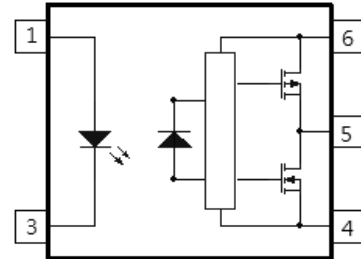

PIN DEFINITION

	6.VCC
1.Anode	5.VO
3.Cathode	4.GND

Package

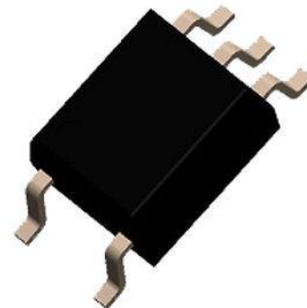

DC Input, 0.8A, Gate Driver Photo Coupler

ABSOLUTE MAXIMUM RATINGS				
PARAMETER	SYMBOL	VALUE	UNIT	Note
INPUT				
Forward Current	IF	25	mA	
Peak Forward Current	IFP	50	mA	1
Peak Transient Current	IF(trans)	1	A	2
Operating Frequency	f	150	kHz	3
Reverse Voltage	VR	5	V	
Input Power Dissipation	PI	100	mW	
OUTPUT				
Supply Voltage	VCC	35	V	
Output Voltage	VO	35	V	
Peak Output Current	IO	0.8	A	
Output Power Dissipation	PO	250	mW	
COMMON				
Total Power Dissipation	Ptot	295	mW	
Isolation Voltage	Viso	3750	Vrms	4
Operating Temperature	Topr	-40~100	°C	
Storage Temperature	Tstg	-55~150	°C	
Soldering Temperature	Tsol	260	°C	5

Note 1. 50% duty, 1ms P.W

Note 2. $\leq 1\mu\text{s}$ P.W, 300pps

Note 3. Exponential waveform with pulse width $\leq 0.3\ \mu\text{s}$, $T_a = 100^\circ\text{C}$

Note 4. AC For 1 Minute, R.H. = 40 ~ 60%

Note 5. For 10 seconds

TRUTH TABLE			
LED	VDD-VSS "Positive Going" (Turn-on)	VDD-VSS "Negative Going" (Turn-off)	VO
Off	0V to 30V	0V to 30V	Low
On	0V to 11.5V	0V to 10V	Low
On	11.5V to 13.5V	10V to 12V	Transition
On	13.5V to 30V	12V to 30V	High

DC Input, 0.8A, Gate Driver Photo Coupler**RECOMMENDED OPERATION CONDITIONS**

PARAMETER	SYMBOL	MIN.	MAX.	UNIT
Operating Temperature	TA	-40	100	°C
Supply Voltage	VCC	10	30	V
Input Current (ON)	IF(ON)	7	16	mA
Input Voltage (OFF)	VF(OFF)	0	0.8	V

ELECTRICAL OPTICAL CHARACTERISTICS (VCC=30V, VEE=GND, TA=25°C unless specified otherwise)

PARAMETER	SYMBOL	MIN.	TYP.	MAX.	UNIT	TEST CONDITION	NOTE
INPUT CHARACTERISTICS							
Forward Voltage	VF	-	1.38	1.8	V	IF=10mA	
Reverse Current	IR	-	-	10	μA	VR=5V	
Input Capacitance	C _{in}	-	13	-	pF	V=0, f=1MHz	
OUTPUT CHARACTERISTICS							
High Level Supply Current	ICCH	-	1.9	3	mA	IF= 7mA to 10mA, VO= Open	
Low Level Supply Current	ICCL	-	2.1	3	mA	VF = 0 to 0.8V, VO= Open	
TRANSFER CHARACTERISTICS							
High Level Output Voltage	VOH	VCC-0.6	VCC-0.35	-	V	IF= 10mA, IO= -100mA	
Low Level Output Voltage	VOL	-	VEE+0.25	VEE+0.4	V	IF= 0mA, IO= 100mA	
High Level Output Current	IOPH	-0.3	-	-	A	VO= VCC-3.0V	
		-0.8	-	-	A	VO= VCC-6.0V	
Low Level Output Current	IOPL	0.3	-	-	A	VO= VEE+1.5V	
		0.8	-	-	A	VO= VEE+2.5V	
Input Threshold Current	IFLH	-	2	5	mA	IO= 0mA, VO> 5V	
Input Threshold Voltage	VFHL	0.8	-	-	V	IO= 0mA, VO< 5V	
Under Voltage Lockout Threshold	VUVLO+	6.9	7.8	8.7	V	IO= 10mA, VO> 5V	
	VUVLO-	5.9	6.7	7.5	V	IO= 10mA, VO< 5V	
Isolation Resistance	R _{iso}	10 ¹²	10 ¹⁴	-	Ω	DC500V, 40 ~ 60% R.H.	
Floating Capacitance	C _{IO}	-	1.0	-	pF	V=0, f=1MHz	

MPC-155E

DC Input, 0.8A, Gate Driver Photo Coupler

ELECTRICAL OPTICAL CHARACTERISTICS (VCC=30V, VEE=GND, TA=25°C unless specified otherwise)							
PARAMETER	SYMBOL	MIN.	TYP.	MAX.	UNIT	TEST CONDITION	NOTE
SWITCHING CHARACTERISTICS							
Propagation Delay Time to Output Low Level	TPHL	-	130	200	ns	IF= 7 to 16mA, CL= 1nF, RL= 30Ω, f= 10kHz, Duty = 50%, TA= 25 °C	
Propagation Delay Time to Output High Level	TPLH	-	120	200	ns		
Pulse Width Distortion	TPHL-TPLH	-	10	70	ns		
Propagation Delay Skew	tPSK	-100	-	100	ns		
Rise Time	tr	-	30	-	ns		
Fall Time	tf	-	30	-	ns		
UVLO Turn On Delay	tUVLO(ON)	-	1.6	-	μs	IF= 10mA, VO> 5V	
UVLO Turn Off Delay	tUVLO(OFF)	-	0.4	-	μs	IF= 10mA, VO< 5V	
Common Mode Transient Immunity at Logic High	CMH	-20	-	-	kV/μs	IF=7 to 16mA VCC= 30V, TA= 25 °C, VCM= 2kV	
Common Mode Transient Immunity at Logic Low	CML	20	-	-	kV/μs	IF=0mA VCC= 30V, RL, TA= 25 °C, VCM= 2kV	

CHARACTERISTIC CURVES

Fig.1 Forward Current vs. Forward Voltage

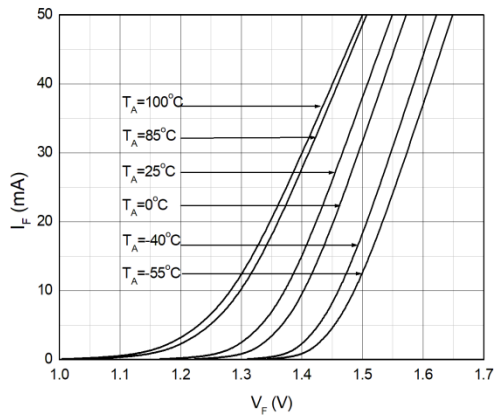

Fig.2 Forward Voltage vs. Ambient Temperature

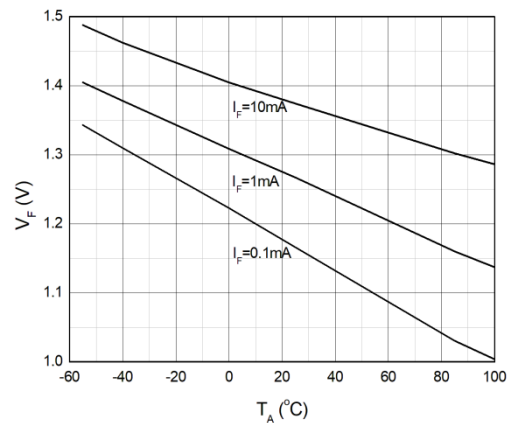

Fig.3 Supply Current vs. Ambient Temperature

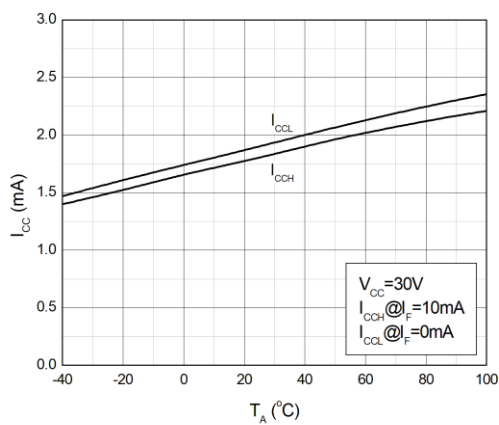

Fig.4 Supply Current vs. Supply Voltage

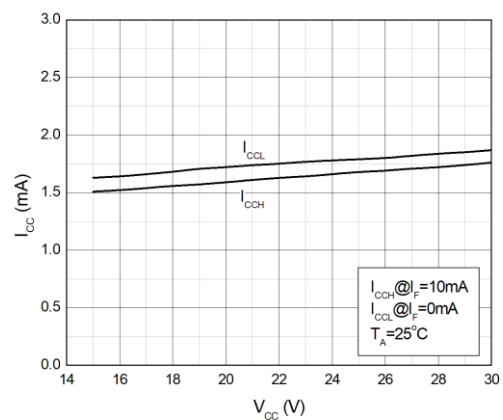

Fig.5 High Level Output Voltage vs. High Level Output Current

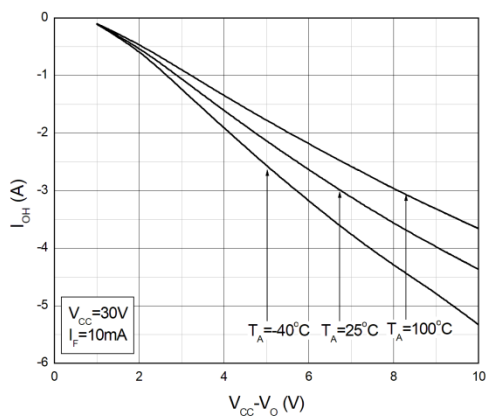
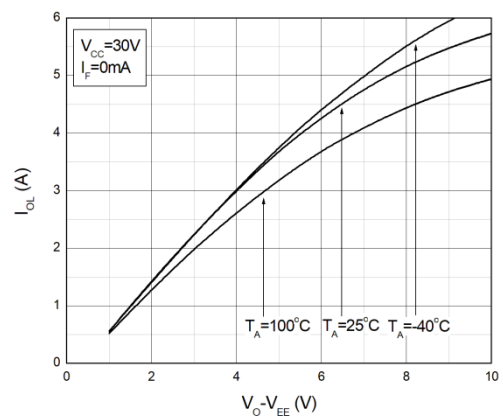

Fig.6 Low Level Output Voltage vs. Low Level Output Current



CHARACTERISTIC CURVES

Fig.7 High Level Output Voltage vs. Ambient Temperature

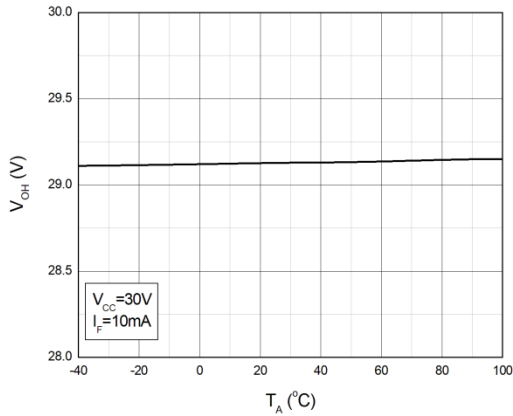

Fig.8 Low Level Output Voltage vs. Ambient Temperature

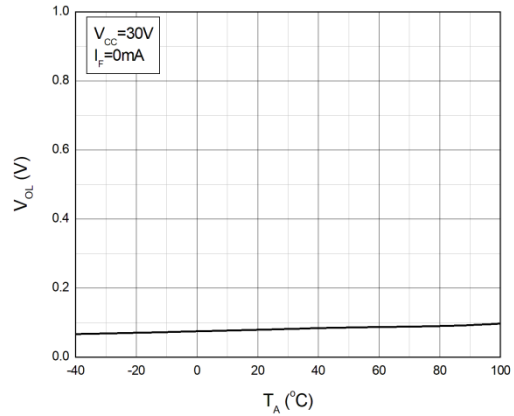

Fig.9 Output Voltage vs. Forward Current

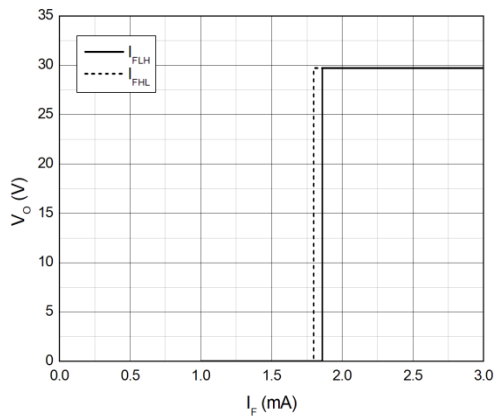

Fig.10 Output Voltage vs. Supply Voltage

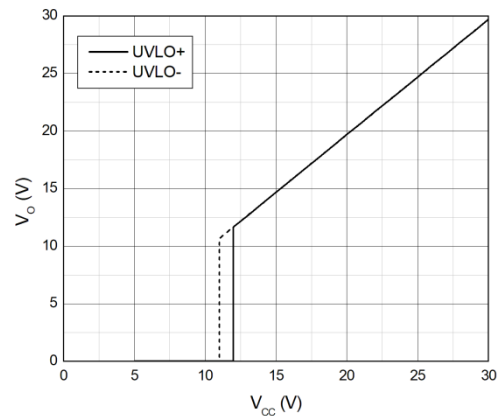

Fig.11 Forward Current vs. Ambient Temperature

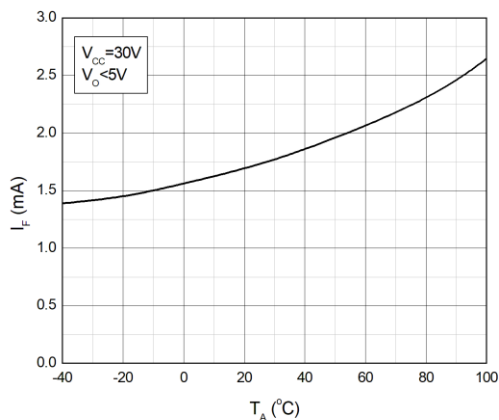
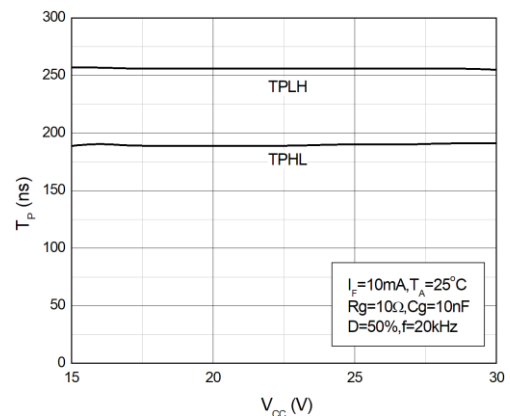

Fig.12 Propagation Delay vs. Supply Voltage



CHARACTERISTIC CURVES

Fig.13 Propagation Delay vs. Forward Current

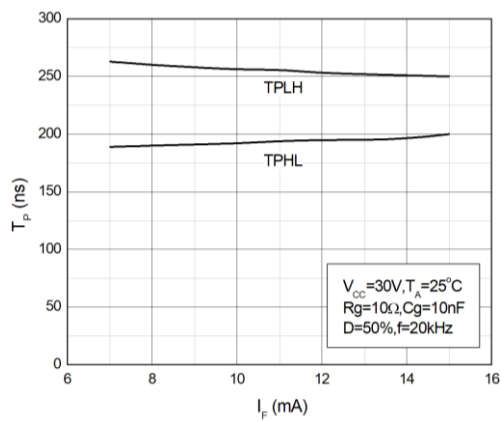

Fig.14 Propagation Delay vs. Ambient Temperature

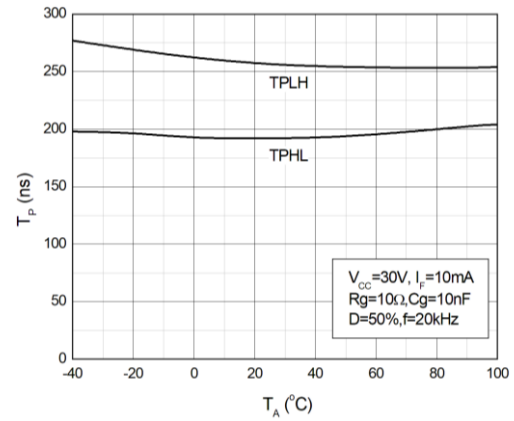

Fig.15 Propagation Delay vs. Load Resistance

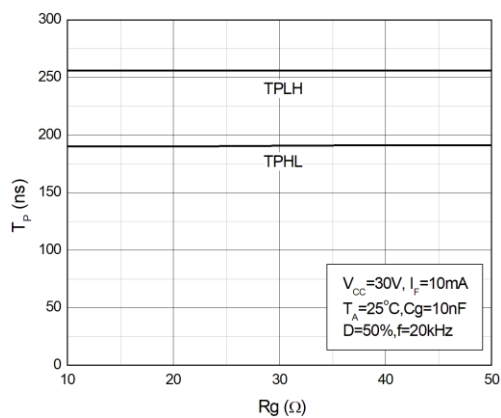
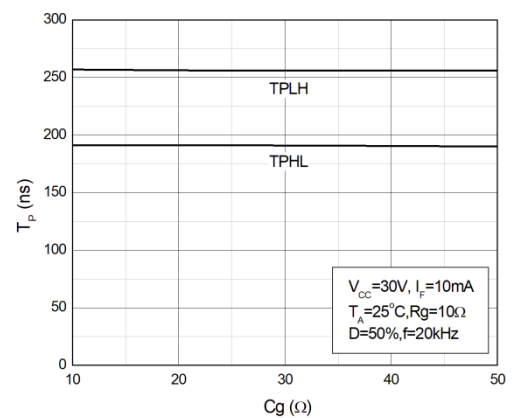

Fig.16 Propagation Delay vs. Load Capacitance



TEST CIRCUITS

Fig.17 Test Circuits for IOH

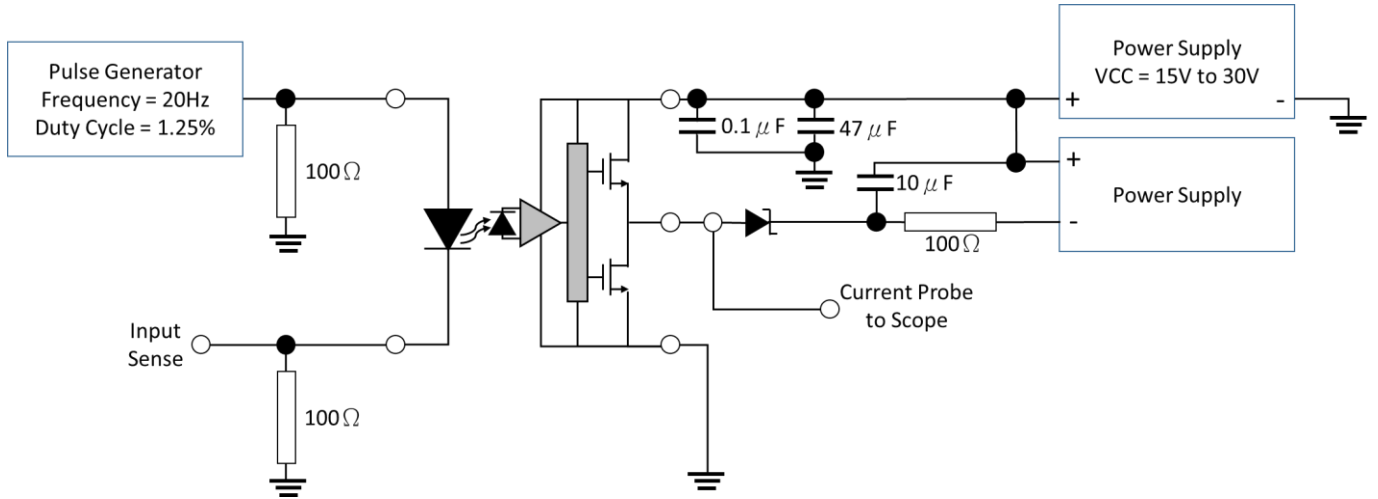
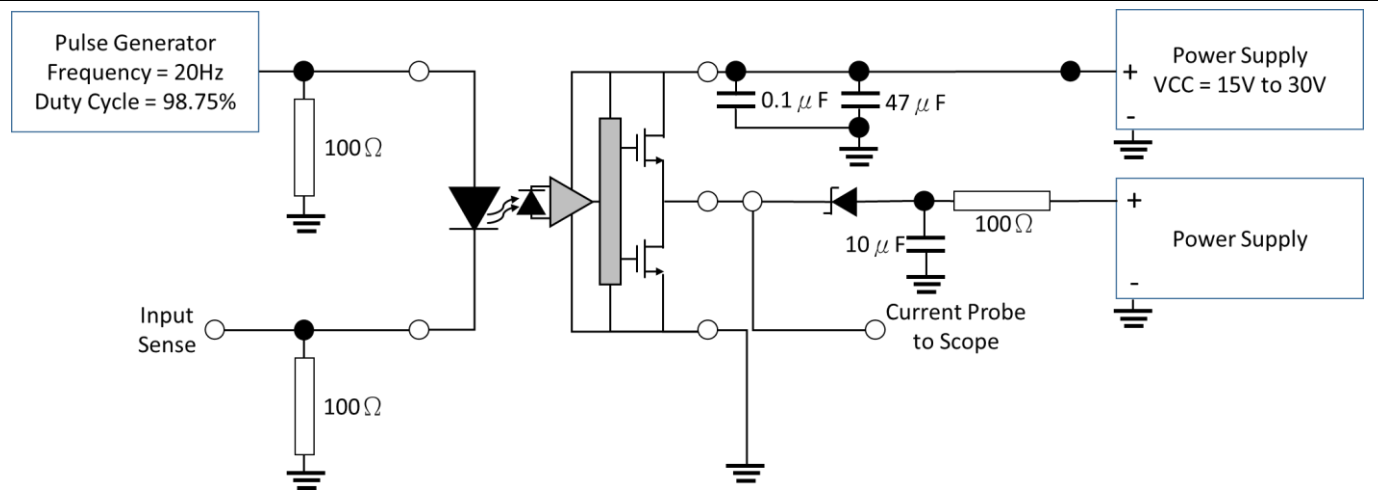

Fig.18 Test Circuits for IOL



TEST CIRCUITS

Fig.19 Test Circuits for TPHL, TPLH, tr, tf

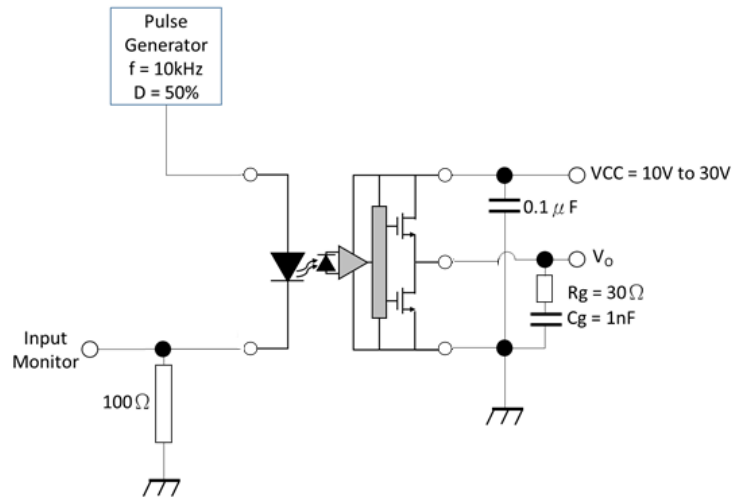
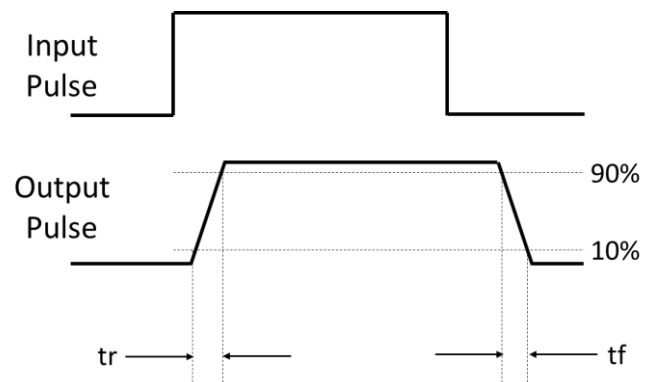
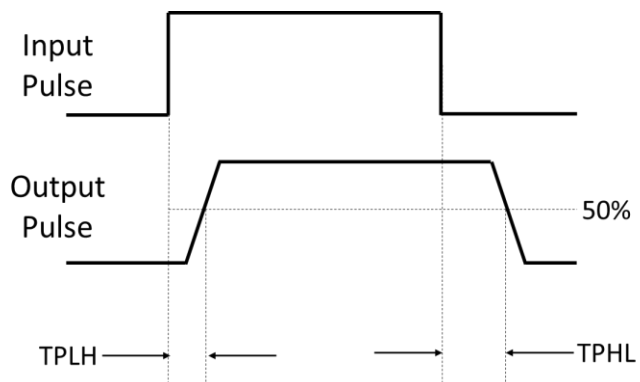

Fig.20 Waveforms of TPHL, TPLH, tr, tf



TEST CIRCUITS

Fig.21 Test Circuits for Common Mode Transient Immunity

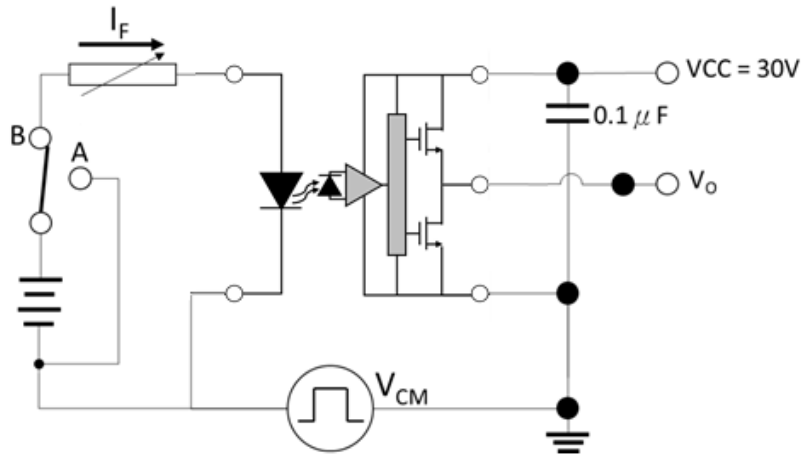
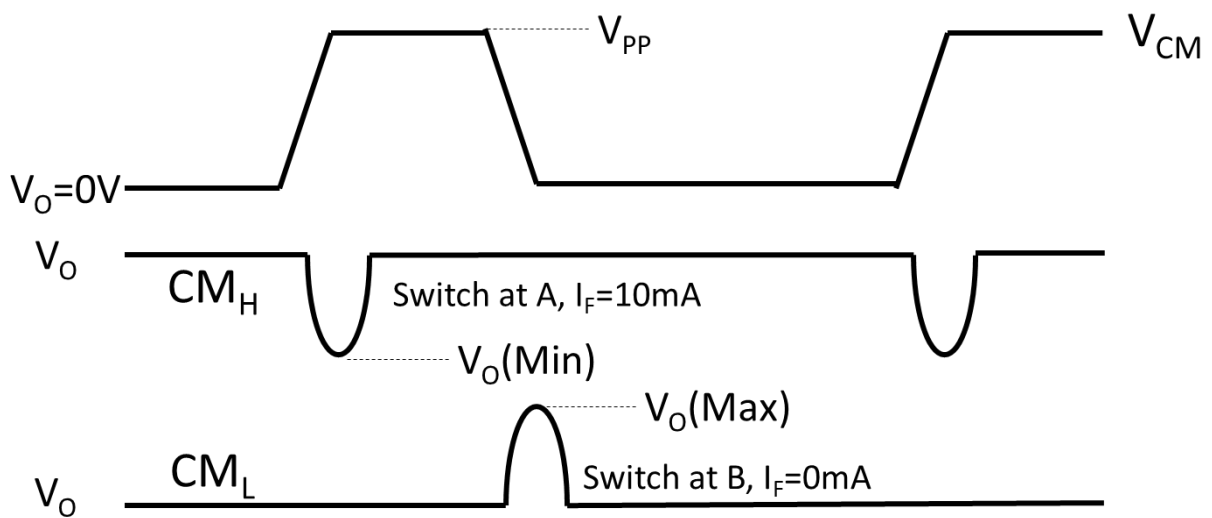

Fig.22 Waveforms of Common Mode Transient Immunity



MPC-155E

DC Input, 0.8A, Gate Driver Photo Coupler

PACKAGE DIMENSIONS (Dimensions in mm unless otherwise stated)

Surface Mount Lead Forming

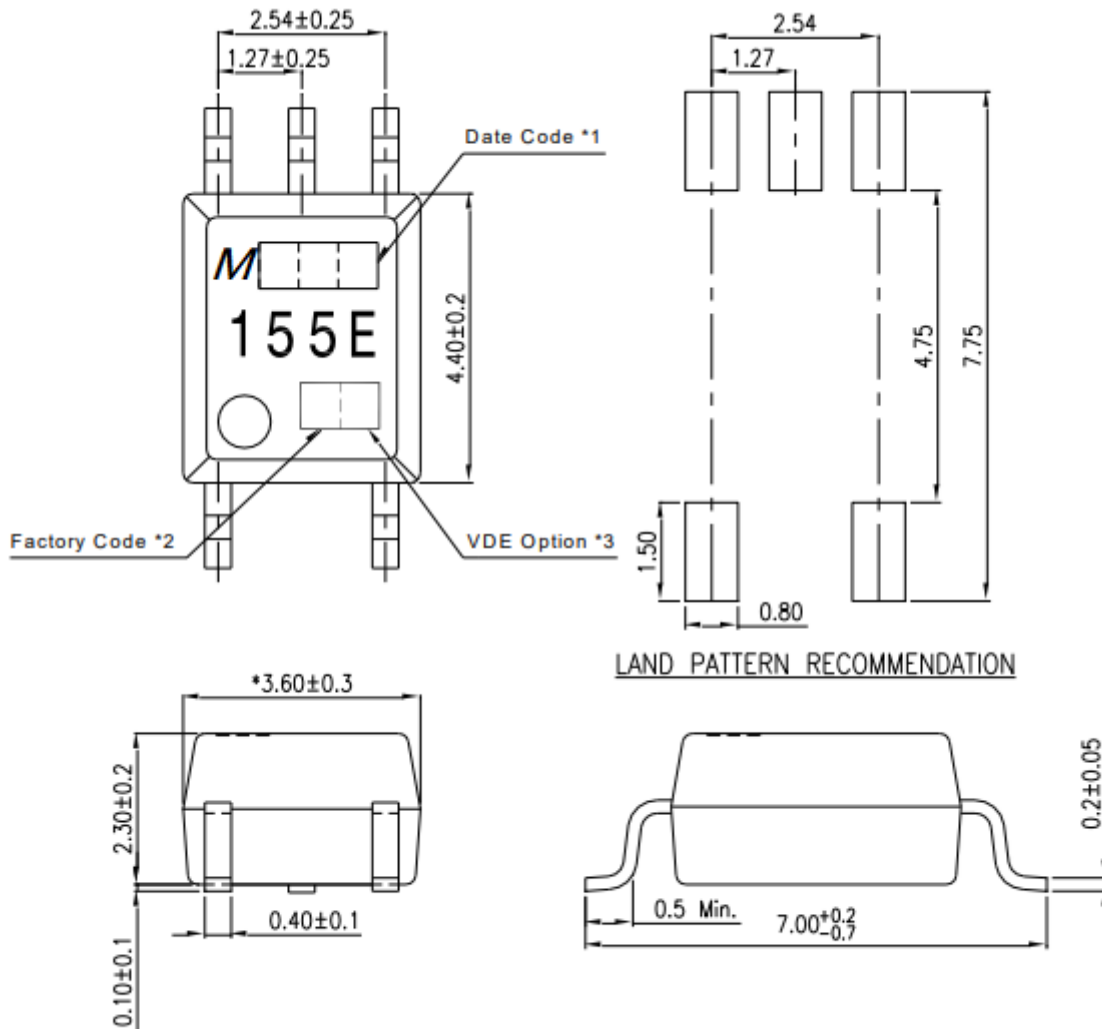

MPC-155E

DC Input, 0.8A, Gate Driver Photo Coupler

Carrier Tape Specifications (Dimensions in mm unless otherwise stated)

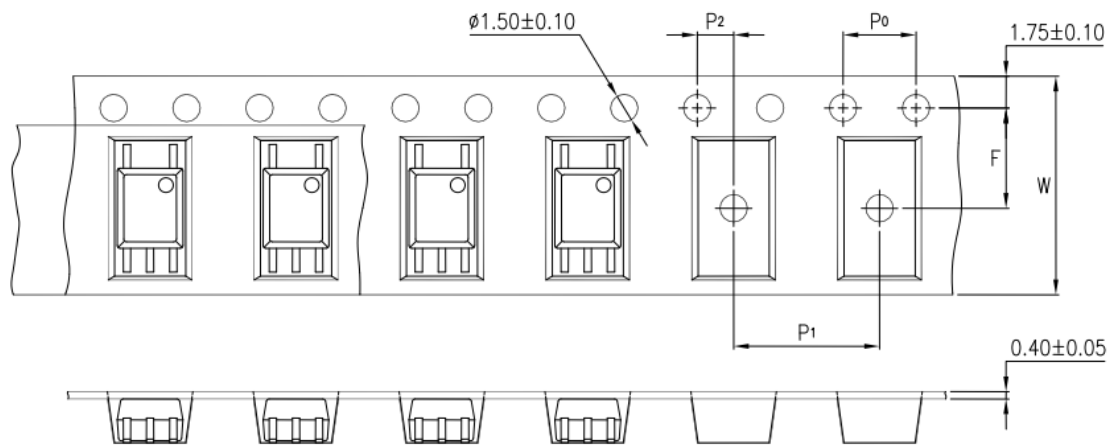

Description	Symbol	Dimension in mm (inch)
Tape wide	W	12±0.3 (0.47)
Pitch of sprocket holes	P ₀	4±0.1 (0.15)
Distance of compartment	F	5.5±0.1 (0.217)
	P ₂	2±0.1 (0.079)
Distance of compartment to compartment	P ₁	8±0.1 (0.315)

PACKING QUANTITY

Option	Description	Quantity
None	MPL-155E Series SOP-5	3000 Units/Reel

REFLOW INFORMATION

REFLOW PROFILE

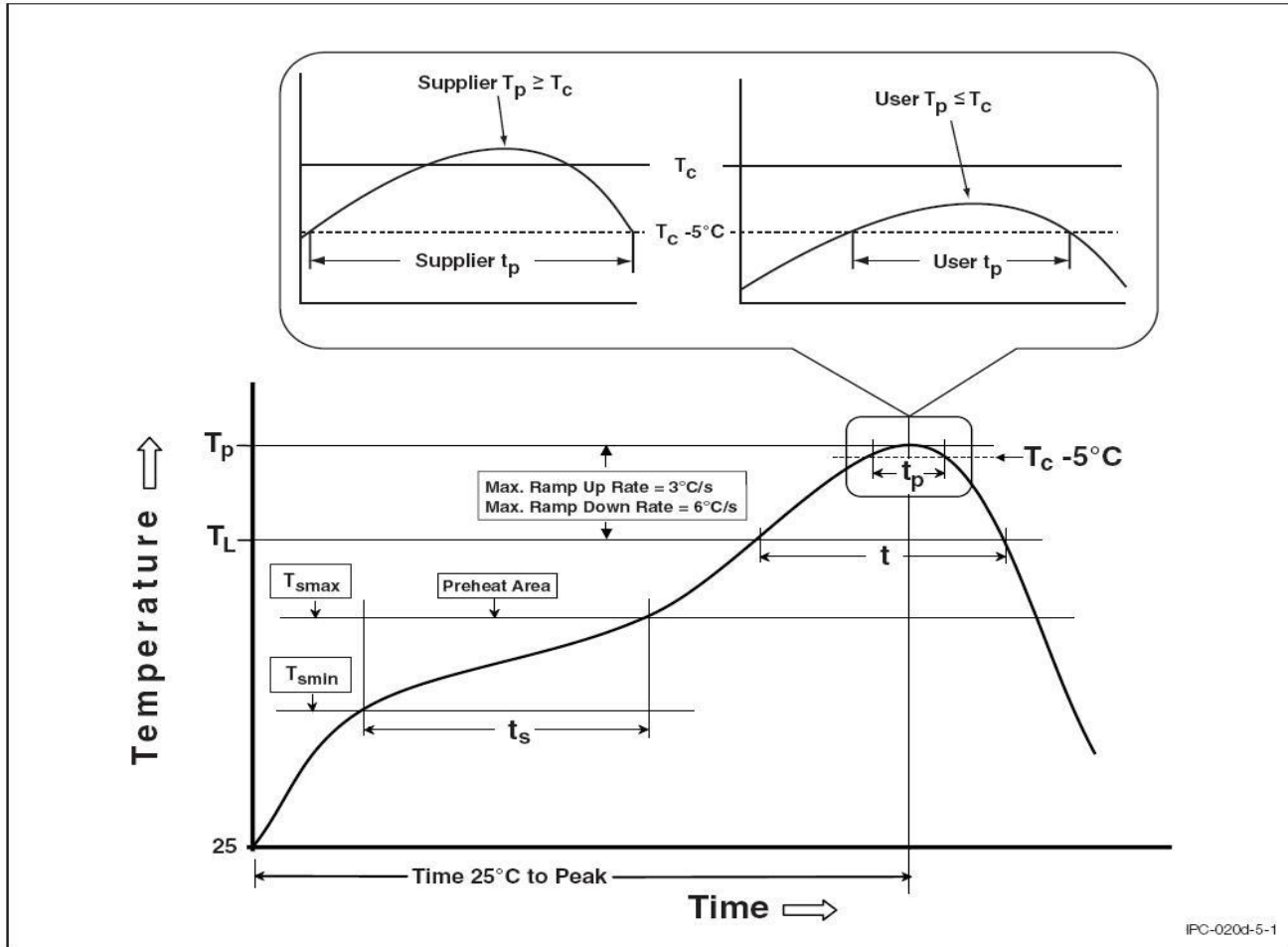

Profile Feature	Sn-Pb Assembly Profile	Pb-Free Assembly Profile
Temperature Min. (T_{smin})	100	150°C
Temperature Max. (T_{smax})	150	200°C
Time (t_s) from (T_{smin} to T_{smax})	60-120 seconds	60-120 seconds
Ramp-up Rate (t_L to t_P)	3°C/second max.	3°C/second max.
Liquidous Temperature (T_L)	183°C	217°C
Time (t_L) Maintained Above (T_L)	60 – 150 seconds	60 – 150 seconds
Peak Body Package Temperature	235°C +0°C / -5°C	260°C +0°C / -5°C
Time (t_p) within 5°C of 260°C	20 seconds	30 seconds
Ramp-down Rate (T_P to T_L)	6°C/second max	6°C/second max
Time 25°C to Peak Temperature	6 minutes max.	8 minutes max.

DISCLAIMER

- WISELITE is continually improving the quality, reliability, function and design. WISELITE reserves the right to make changes without further notices.
- The characteristic curves shown in this datasheet are representing typical performance which are not guaranteed.
- WISELITE makes no warranty, representation or guarantee regarding the suitability of the products for any particular purpose or the continuing production of any product. To the maximum extent permitted by applicable law, WISELITE disclaims (a) any and all liability arising out of the application or use of any product, (b) any and all liability, including without limitation special, consequential or incidental damages, and (c) any and all implied warranties, including warranties of fitness for particular
- The products shown in this publication are designed for the general use in electronic applications such as office automation, equipment, communications devices, audio/visual equipment, electrical application and instrumentation purpose, non-infringement and merchantability.
- This product is not intended to be used for military, aircraft, automotive, medical, life sustaining or lifesaving applications or any other application which can result in human injury or death.
- Please contact WISELITE sales agent for special application request.
- Immerge unit's body in solder paste is not recommended.
- Parameters provided in datasheets may vary in different applications and performance may vary over time. All operating parameters, including typical parameters, must be validated in each customer application by the customer's technical experts. Product specifications do not expand or otherwise modify WISELITE's terms and conditions of purchase, including but not limited to the warranty expressed therein.
- Discoloration might be occurred on the package surface after soldering, reflow or long-time use. It neither impacts the performance nor reliability.